

# AESCULAP® **SO**.line® KERRISON bone punches

Such **Q**uality!



# AESCULAP® SQ.line® KERRISON

Experience a new quality of bone punches

## "Badly performing punches?"

Poorly functioning bone punches are a common challenge for neuro- / spine surgeons and this pain is often accepted as "normal".

### Increased performance and durability

SQ.line® KERRISON punches are produced with a harder material and are covered with the Noir® plus coating, bearing a low friction coefficient (1) and reduces the risk of intraoperative jamming (2) due to sticking of bone or tissue.

So Qonsistent!



## "Pain from bone punching?"

Manual bone punching can be tiring, painful and uncomfortable.

### Ergonomic handle design

SQ.line® KERRISON punches are designed with a handle that offers a high ergonomic comfort by reducing the pressure peaks (areas with highest surface pressure) (7).

So Qomfortable!





### "Difficult to clean?"

Surgical instruments are becoming more complex and, unsurprisingly, more difficult to clean. This can increase CSSD workload, time required and therefore reduce efficiency.

### Optimized for sufficient cleaning

With **SO**.line® KERRISON punches manual pre-cleaning is not required. They are fully machine washable and 100% of interviewed customers agreed they have a "good to very good" design for visual inspection (9).

So **Q**lean!



### "The dis-/assembly is awkward and time-consuming?"

Dis-/assembly of instruments can be very time consuming and therefore expensive. Intra-operative cleaning is a challenge.

### Dis-/assembled within seconds

**SO**.line® KERRISON punches enable a fast and intuitive dis-/assembly, saving potentially more than one minute per reprocessed bone punch (9)!

So **Q**onvenient!

# AESCULAP® SQ.line® KERRISON

Such Quality!

## So Qonsistent!

Designed to withstand the rigors of complex procedures, with an increased durability and consistency.

- More robust (1)  
(Up to 300 % more punches until repair / blunt)
- Less jamming (2)  
(0 % jamming in laboratory test)
- Controlled and fast ejection of bone and tissue (8)  
(Confirmed by 100 % of users)
- Reduced light reflections (6)  
(approx. 50 % less light reflection compared to non-coated punches at the working end)

Flat surface for controlled and fast removal of bone and tissue from the jaw (8).



All SQ.line® KERRISON bone punches are equipped with an ejector.

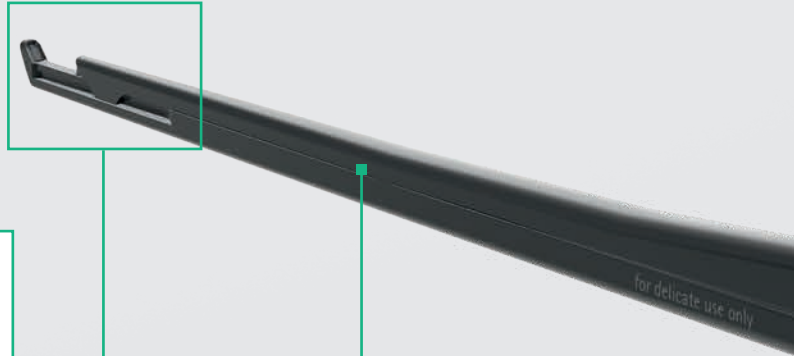

Noir® plus coating for reduced occurrence of light reflections (6) plus reduced risk of jamming (2).

## So **Q**omfortable!



The **SQ.line®** KERRISON's ergonomic handle design is intended to reduce pressure points for comfortable use during extended surgical procedures.

- Superior comfort for fore- and back-hand punching (8)  
(attested by majority of users in comparison to predecessor items and a leading competitor)
- Reduction of pressure peaks (areas with highest surface pressure) by 27% (7)  
(compared to a leading competitor)
- Suitable for many hand sizes (8)  
(tested with 12 surgeons with gloves sizes from S – L)

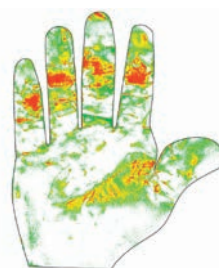

— Highest surface pressure  
→ maximum discomfort

— Lowest surface pressure  
→ maximum comfort

Measurement of **SQ.line®** KERRISON's surface pressure distribution with a pressure measuring foil.

# AESCULAP® SQ.line® KERRISON

Such Quality!

So Qlean!

SQ.line® KERRISON was designed to enhance instrument processing, cleaning and efficiency.

- Easy-to-clean design (9)  
(upward punching models are semi-detachable, downward punching models are fully detachable)
- Fully machine washable  
(cleaning validation without manual pre-cleaning)
- Good to very good design for visual inspection (9)  
(confirmed by 100% of interviewed customers)



Easy-to-clean design of the external spring.

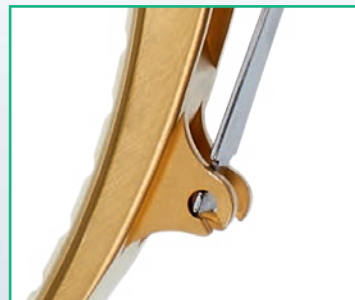



Easy identification of relevant product information (9)

## So **Q**onvenient!

The **SQ**.line® KERRISON punch's semi-detachable design makes reprocessing and dis-/assembly easier and more intuitive. This feature also benefits intraoperative cleaning.

- Dis-/assembled within seconds (9) (result of usability test with CSSD staff)
- Large time-saving potential (9) (84% time saving potential for dis-/assembly compared to a leading competitor)
- Intuitive dis-/assembly (9) (confirmed by interviewed CSSD staff; 80% disassembly and >90% assembly)



Lever automatically closes when the front handle is pressed.

# AESCULAP® SQ.line® KERRISON

## Portfolio overview

### Product range

- Working lengths: 180, 200, 230, 280 mm
- Jaw widths: 1 – 6 mm
- Footplates: standard and thin
- Jaw angles: 130° and 90°
- Jaw positions:  
upward and downward punching
- Jaw openings:  
10 mm and 15 mm jaw opening



Standard punch,  
130° upwards opening





Standard punch, 15 mm jaw opening, 130° upwards opening

Thin foot punch, 130° downwards opening

Standard punch, 130° downwards opening

Thin foot punch, 130° upwards opening

# AESFULAP<sup>®</sup> SQ.line<sup>®</sup> KERRISON

## Racks

Protecting the cutting edges and surfaces of instruments during transport is essential to ensure durability. That's why we've designed the SQ.line<sup>®</sup> KERRISON racks, which offer increased protection during transport (10), ensuring that the bone punches consistently arrive at the operating room in good condition.

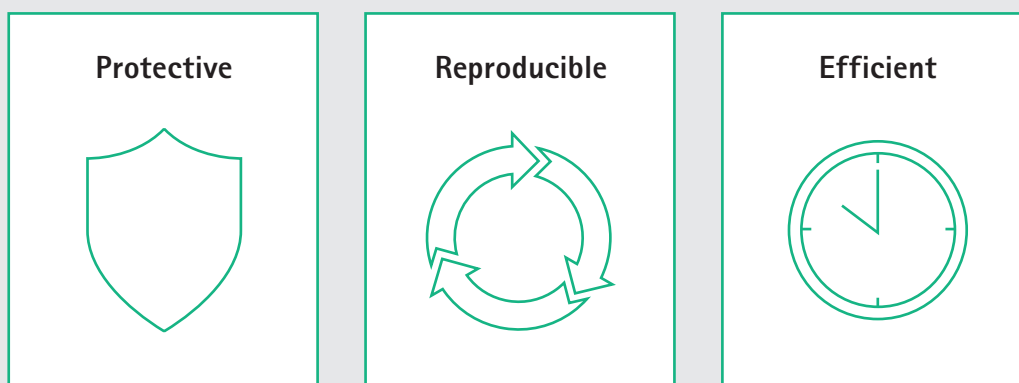

- Increased protection of cutting edges and surfaces against transport damages (compared to transportation w/o rack) (10).  
(SQ.line<sup>®</sup> KERRISON bone punch shake test)
- Suitable for the entire instrument cycle (mechanical cleaning, sterilisation, instrumentation).  
(SQ.line<sup>®</sup> KERRISON cleaning and sterilisation validation)
- The racks are designed with cleaning positions and sterilisation positions.
- Suitable for the entire SQ.line<sup>®</sup> KERRISON portfolio in all lengths and sizes.
- Racks including punches are suitable for standard instrument trays with a inner height of 92 mm, even including a lid.

We recommend AESFULAP<sup>®</sup> JF/JG trays with an inner length of min. 404 mm and an inner height of 92 mm or JJ trays with an inner length of min. 401 mm and an inner height of 102 mm.

### Cleaning position

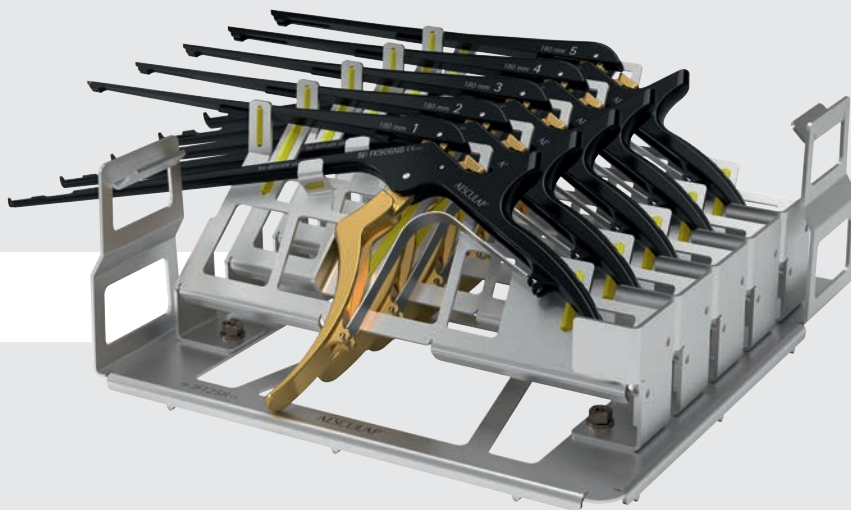

**SQ.line®** KERRISON racks for five punches  
Removable from the tray for instrumentation in the OR (11).  
**JF125R** (209 mm x 231 mm x 91 mm)

### Sterilisation position

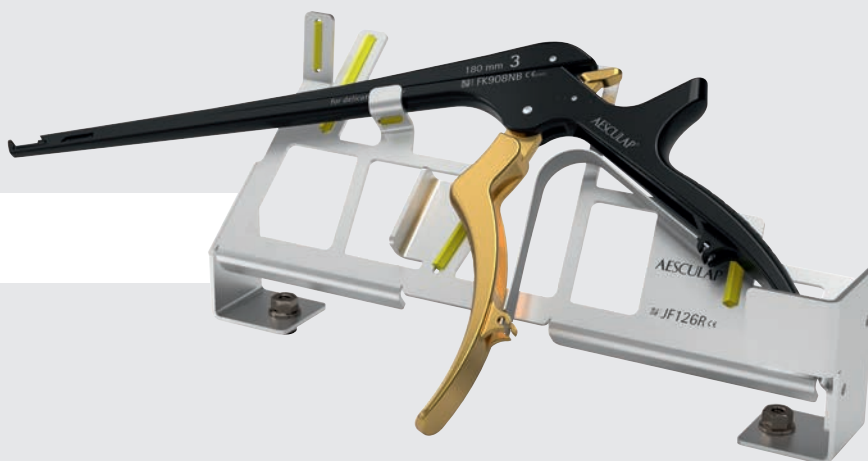

**SQ.line®** KERRISON racks for one punch  
Fixed to the tray with two screws.  
**JF126R** (192 mm x 68 mm x 83 mm)

# AESCU LAP<sup>®</sup> SQ.line<sup>®</sup> KERRISON

Positive influence on instrument cycle

## Utilization

**Punches:** Less intraoperative jamming, intraoperative cleaning possible (2)

**Racks:** Suitable for instrumentation (only JF125R) (11)

## Sterile Supply

**Racks:** Increased protection of cutting edges and surfaces against transport damages (10)

## Storage

**Racks:** Punches are stored in rack, ready for the next operation

## Sterilisation

**Racks:** Defined sterilisation position in racks

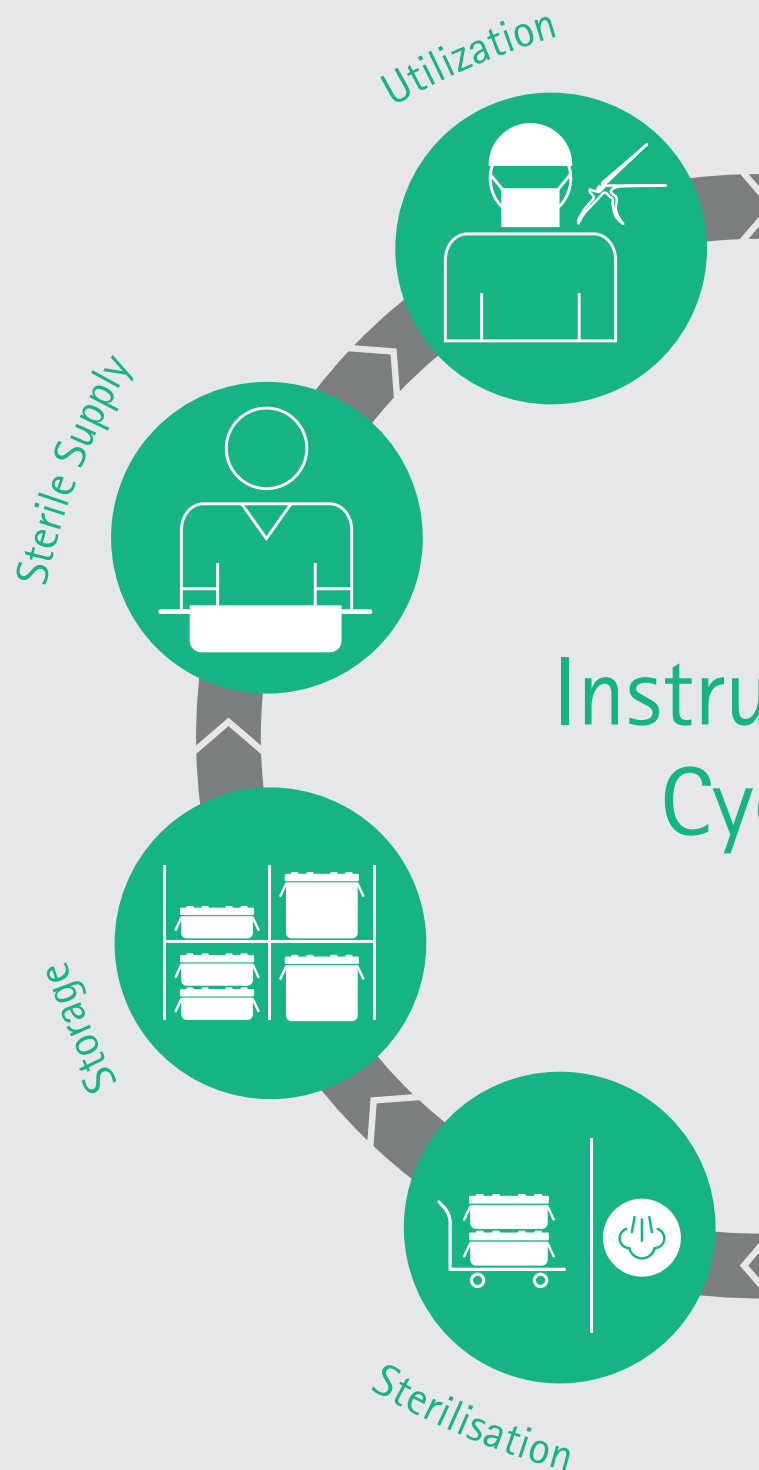

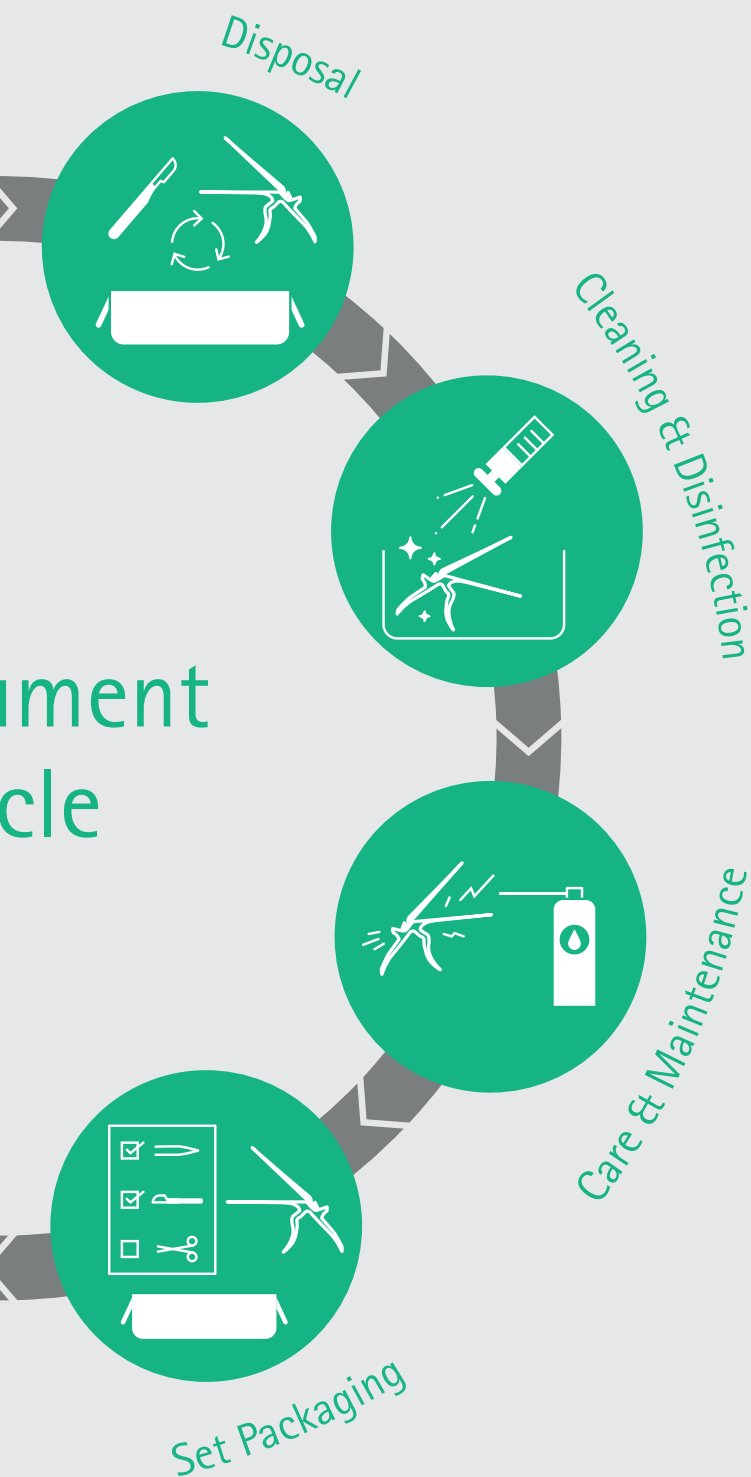

## Disposal

**Punches:** Fast, intuitive tool-free disassembly

**Racks:** OR staff sorts punches directly into rack in defined cleaning position, no need to prepare in CSSD for cleaning

## Cleaning & Disinfection

**Punches:** Fully machine washable, no pre-cleaning required

**Racks:** Defined cleaning position in rack for the reduction of rinsing shades

## Care & Maintenance

**Punches:** Good for visual inspection (9)  
Fast and intuitive assembly (9)

No pairing for upwards punching models required  
No manual lubrication required when using surgical milk instrument lubrication (4)





## Set Packaging

**Racks:** Punches are packed directly on rack ready for sterilisation

# AESCALAP® SQ.line® KERRISON

## Portfolio overview



Jaw position	Working length	Jaw width	KERRISON regular foot	KERRISON thin foot	KERRISON 15 mm jaw
130° upwards 	180 mm	1 mm	FK900NB	FK906NB	-
		2 mm	FK901NB	FK907NB	-
		3 mm	FK902NB	FK908NB	-
		4 mm	FK903NB	FK909NB	-
		5 mm	FK904NB	FK910NB	-
	200 mm	1 mm	FK960NB	FK961NB	-
		2 mm	FK913NB	FK962NB	FK970NB
		3 mm	FK914NB	FK963NB	FK982NB
		4 mm	FK915NB	FK964NB	FK983NB
		5 mm	FK916NB	FK965NB	FK984NB
		6 mm	FK917NB	-	-
	230 mm	1 mm	FK918NB	FK929NB	-
		2 mm	FK919NB	FK925NB	-
		3 mm	FK920NB	FK926NB	-
		4 mm	FK921NB	FK927NB	-
		5 mm	FK922NB	FK928NB	-
	280 mm	1 mm	FK981NB	FK980NB	-
		2 mm	FK986NB	FK976NB	-
		3 mm	FK987NB	FK977NB	-
		4 mm	FK988NB	FK978NB	-
		5 mm	FK989NB	FK979NB	-
90° upwards 	200 mm	1 mm	FK090NB	-	-
		2 mm	FK091NB	-	-
		3 mm	FK092NB	-	-
		4 mm	FK093NB	-	-
		5 mm	FK094NB	-	-
130° downwards 	200 mm	1 mm	FK990NB	FK995NB	-
		2 mm	FK991NB	FK996NB	-
		3 mm	FK992NB	FK997NB	-
		4 mm	FK993NB	FK998NB	-
		5 mm	FK994NB	FK999NB	-
90° downwards 	200 mm	1 mm	FK095NB	-	-
		2 mm	FK096NB	-	-
		3 mm	FK097NB	-	-
		4 mm	FK098NB	-	-
		5 mm	FK099NB	-	-

Width (mm)    □ 1 mm    □ 2 mm    □ 3 mm    □ 4 mm    □ 5 mm    □ 6 mm

## References

- (1) Manual cutting endurance test. Three samples of two worst-case SQ.line® KERRISONS and previous Aesculap KERRISONS each were used to cut lamb spine 25 000 times. All SQ.line® KERRISONS were perfectly functioning after the test cycles without repair and thereby showed up to three times increased durability.
- (2) Jamming test. Five samples of three different SQ.line® KERRISONS and previous Aesculap KERRISONS were tested on lamb spine with 50 repeated punches. The SQ.line® KERRISON showed no jamming for the duration of the test.
- (3) Destructive test. The required destructive force was measured for five samples of two worst-case SQ.line® KERRISONS and previous Aesculap KERRISONS each, biting on a metal plate. The SQ.line® KERRISONS withstood significantly greater forces on the cutting edge than the corresponding previous Aesculap KERRISONS.
- (4) Milk lubrication test. Three samples of the SQ.line® KERRISONS were lubricated with an emulsion of water and surgical milk instrument lubricant. Afterwards, the samples were able to successfully punch a test card 50 times without jamming between the main part and the slider.
- (5) Performance test aged. Five samples of the most delicate SQ.line® KERRISON bone punch with three corresponding previous Aesculap KERRISONS were compared. After aging the SQ.line® KERRISONS by 500 reprocessing cycles, they successfully passed all defined test criteria for the wearing parts. The SQ.line® KERRISON outperformed the previous Aesculap KERRISONS.
- (6) Gloss value measurement. The gloss values of two new and five aged SQ.line® KERRISONS were measured on three defined areas from two different angles each. The results were compared to the values of uncoated Aesculap KERRISONS. The processing had no significant influence on the reflection behavior. The Noir® plus coating reduced reflections on the slider by 70% to 86%, on the main part by 47% to 63% and on the handle by 19% to 76% depending on the direction of measurement.
- (7) Handle comfort evaluation report. The SQ.line® KERRISON handle was compared in terms of comfort during use to its predecessor and one of its competitor's handle. It is based on the visualization of prevailing surface pressure distributions during the actuation by means of pressure measuring foil. The SQ.line® KERRISON showed smaller areas of high surface pressure and a more homogeneous pressure distribution.
- (8) Usability test with neurosurgeons. The usability test with neurosurgeons was performed to validate multiple customer requirements in terms of the performance and the ergonomics of SQ.line® KERRISON. The test was performed with 12 neurosurgeons within a simulated clinical environment. The performance and the ergonomic properties were rated positive.
- (9) Usability test with CSSD and OR personnel. The usability test with CSSD and OR personnel was performed to validate multiple customer requirements in terms of the reprocessing and handling of the upwards cutting SQ.line® KERRISON. Ten people with an average CSSD experience of more than five years were interviewed. The suitability for reprocessing and the handling were rated positive.
- (10) The SQ.line® KERRISON shake test was performed to investigate the resistance of the Noir® plus surface to scratches in comparison with the existing bone punches. For this purpose a sieve basket and a SQ.line® KERRISON rack, both containing bone punches, were fixed on a vibrating plate. It could be demonstrated, that the scratching of surface is strongly reduced with the use of the SQ.line® KERRISON racks.
- (11) A usability test for the SQ.line® KERRISON racks was performed to validate the realization of multiple user needs and other requirements. Ten Aesculap employees who have knowledge in storage and reprocessing of surgical instruments and are familiar with general OR techniques and OR environment were interviewed. All users rated the usability of the racks positive.

# AESCULAP® – a B. Braun brand

Aesculap AG | Am Aesculap-Platz | 78532 Tuttlingen | Germany  
Phone +49 7461 95-0 | Fax +49 7461 95-2600 | [www.bbraun.com](http://www.bbraun.com)

The main product trademark "Aesculap" and the product trademarks "SQ.line" and "Noir" are registered trademarks of Aesculap AG. Subject to technical changes. All rights reserved. This brochure may only be used for the exclusive purpose of obtaining information about our products. Reproduction in any form partial or otherwise is not permitted.